

Mini High Performance CCC Instrument for milligrams purification

Dynamic Extractions specializes in offering separation and purification technology, which provides additional capability to chemists who want to purify products from *Discovery* stage through *Research & Development* to *Manufacture*.

The **Mini High Performance CCC (HPCCC)** instrument is based on traditional liquid/liquid partitioning and extends the purification options available to chemists, in *Discovery* and *Development*, who are looking purify samples from 5 milligram - 500 milligram of material.

The equipment is easily connected and interfaced into existing LC equipment and provides options when existing solid phase technology cannot obtain the resolution required or when sample solubility is a problem.

The added advantage of the technique is that it is easily scales to preparative and kilo scale with no requirement to develop the separation method as it is directly transferable from analytical to kilo scale rapidly and easily.

The equipment is fully supported by the **Dynamic Extractions** support team that provides support through training, feasibility studies, method development and direct customer support. This ensures that all customers have peace of mind and confidence in the technique.

Benefits of Mini HPCCC to Chromatographers and Chemists

- High mass and volume injection loadings
- Improved handling of sample solubility issues
- Ease and cost of scale-up
- Extremely low solvent usage
- Total sample recovery
- Reduced sample preparation
- New elution strategies

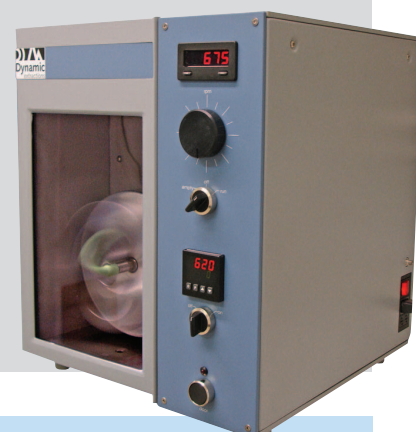

Typical HPCCC applications in medicinal chemistry

- Where solubility of your sample is problematic to your existing RP purification techniques
- Product development where you do not want to redevelop your purification processes at each differing scale
- Where you want to purify target compounds from crude samples, which are early in their chemistry development and can not be handled by other techniques without significant sample preparation

*Solving scale-up and solubility
challenges in liquid chromatography*

Technical Description

The **Dynamic Extractions** equipment is simple in concept and consists of a length of tubing wound in a coil on a drum which is centrifugally rotated in a planetary motion. Separations are achieved by partitioning the sample between two immiscible liquids: a stationary phase, which is retained in the tubing and a mobile phase which is pumped through the tubing.

The operational process is extremely straightforward. The mixture is introduced in the mobile liquid and is separated into its component fractions by the time it emerges at the other end of the tubing. A separation of the mixture occurs, because along the tubing's length there are alternate mixing and settling zones created by the centrifugal forces generated. The order in which the fractions appear depends on how they distribute between the two liquids. The entire sample is recoverable, and highly pure fractions can be obtained since the sample undergoes up to 100,000 mixing and settling steps per hour. This allows the technology to be applied to the separation of substances, which are difficult to purify and/or may be unstable by other existing techniques.

Standard Features

- **Columns** - Analytical - 18 ml
- **Performance** - 240g (2,100 rpm) equipment allowing separations in minutes
- **Ease of use** – Simple interchange of coils allowing differing separation needs to be met quickly.
- **Temperature control** – Ensures reproducible chemistry of separation
- **Safety features**
 - Column door interlock
 - Automatic shutdown on out of balance operation
 - Automatic shutdown on high temperature operation.
- **Low solvent usage** – Typically 10% of that used in an equivalent solid phase separation
- **Low pressure operation** – 60 - 105psi (4 – 7bar)
- **Easy to use** - Simply interfaced to existing LC equipment (pumps, detector and fraction collector etc)

Technical Specifications

Column Volume	18 ml
Sample load per injection	10-300mg
Column Bore (id)	0.8mm
Flow Rate (Max)	2 ml/min

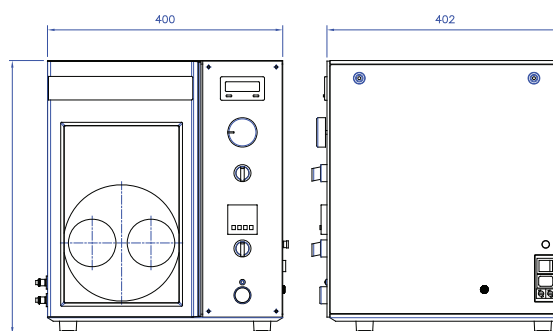

Dimensions

Height	465 mm	18½"
Width	400 mm	16"
Depth	402 mm	16"
Weight	43kg	95lb
Rotor Radius	50 mm	2"
Electrical Supply	115-230V/1ph/50-60Hz	
Power Rating	0.6kVA	